

FIRESTAR™

700C

WAYNE-DALTON COMMERCIAL DOOR SYSTEMS

# FIRESTAR™ 700C SERIES ROLLING STEEL FIRE DOORS

## INSULATED STEEL FIRE DOORS CUT YOUR TOTAL COST

The Wayne-Dalton FireStar Insulated Rolling Steel Fire Door is the innovative solution to safety and fire protection while maintaining thermal integrity.

The 700C Series FireStar door features fire-resistant insulation, making it the ideal choice for exterior openings that require fire doors. Of course, the 700C offers all the features that make the FireStar the most innovative fire door in the industry, including the ability to drop-test and automatically reset the door by anyone without a service call.

FireStar doors also feature forward-thinking designs that outperforms other fire doors with its reliable, long-lasting performance with smooth, quiet operation.



COMMERCIAL DOORS & OPERATORS

- SIZES UP TO 24' WIDE AND 24' HIGH  
(UP TO 324 SQUARE FEET)
- EASY TO TEST WITH STANDARD AUTO-RESET
- R VALUE = 5.0
- UL / FM RATED
- CONFORMS TO NFPA STANDARD 80  
(NATIONAL FIRE PROTECTION ASSOCIATION)

# ROLLING STEEL FIRE DOORS

## 700C SERIES

700C Series FireStar rolling steel fire doors are an innovative solution for safety and fire protection, ideal for use in openings with thermal requirements. Critical elements necessary in the reliable function of fire doors are incorporated as standard features with FireStar's revolutionary design. Smooth slats filled with mineral wool insulation provide a door R Value of 5.0.

### Safety

The FireStar door can be drop tested easily and reset in seconds; no tools or service technicians required. These tests can be done in addition to the required annual inspection by a trained technician. By self-testing throughout the year, you can be even more confident that the door will function safely in the event of fire.

The drop-out mechanism is designed to eliminate down time during drop testing while the viscous governor technology results in smoother, quieter door operation.

### Reliability

FireStar's revolutionary design uses a patent-pending planetary gear on the drop-out mechanism ensuring years of reliable service and drop-out performance. Factory tested and approved for a minimum of 20,000 cycles, the FireStar door can be used and/or tested on a regular basis.

FireStar fire doors have been tested and approved to meet the requirements of well known agencies, such as Underwriters Laboratories and Factory Mutual, and conform to NFPA Standard 80.

### Simplicity

Wayne-Dalton incorporates one standardized component design for all FireStar doors regardless of size, and utilizes fewer parts than other models. This helps to ensure more accurate installations and reduces the possibility of potential service calls in the future.

As an added benefit, eliminating one of the fusible link cables helps the door and surrounding area look cleaner and less cluttered. It also reduces the risk of cable interference with other nearby fixtures.

### Features

- Easy testing and auto-reset
- Innovative planetary gear design approved and tested for a minimum of 20,000 cycles
- R Value = 5.0
- Preassembled drop-out mechanism
- Viscous governor technology
- Single fusible link cable routing
- Standardized component design for all door sizes
- Chain hoist or motor operated
- Available with left-hand or right-hand operation
- UL / FM approved



**Test Device** — FireStar doors feature an easy-to-use release handle.

### FireStar Door Control Device

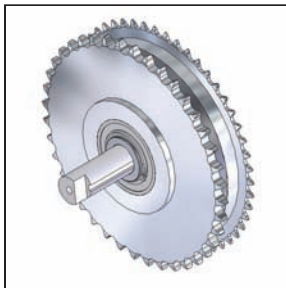

Patent pending.

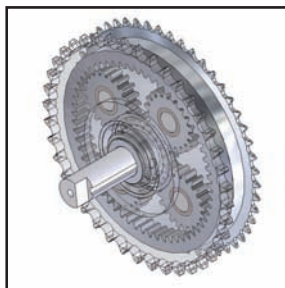

Patent pending.

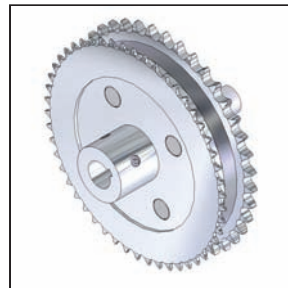

Patent pending.

- Revolutionary Fire Door control device utilizing a planetary gear arrangement to disconnect the operator and drop the door in the event of a fire.
- Easily drop test and reset a fire door without resetting spring tension and rerouting cables.
- Utilizes a viscous governor to drop the door with minimal noise and vibration.

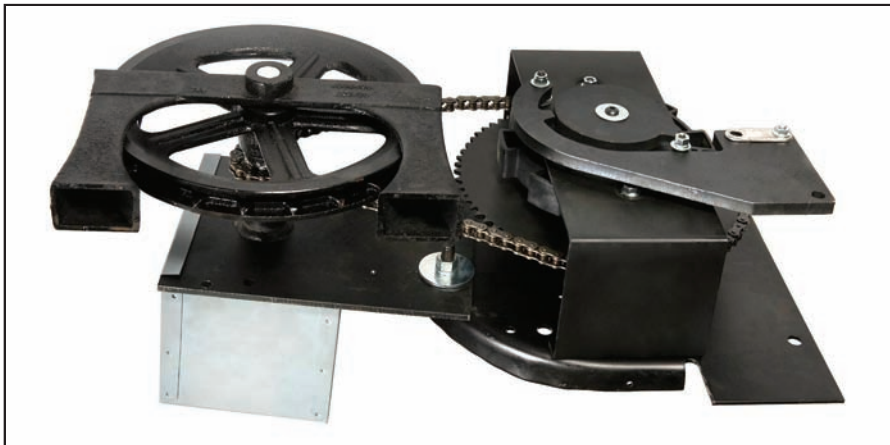

[www.wayne-dalton.com/commercial](http://www.wayne-dalton.com/commercial)

# ROLLING STEEL FIRE DOORS

## 700C SERIES

### CHAIN HOIST OPERATION

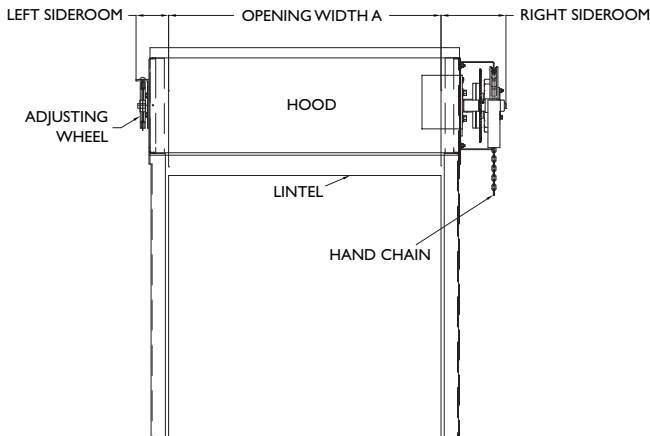

ELEVATION

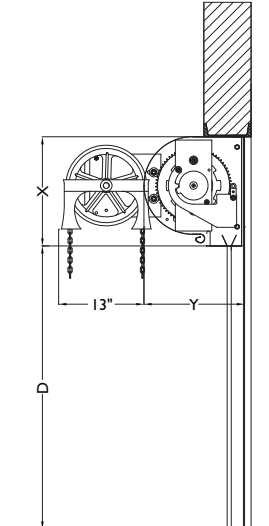

SECTION (UNDER LINTEL)

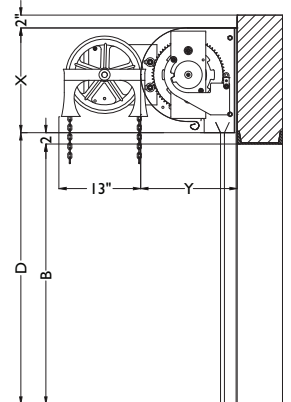

SECTION

### BRACKET MOUNTED POWER UNIT

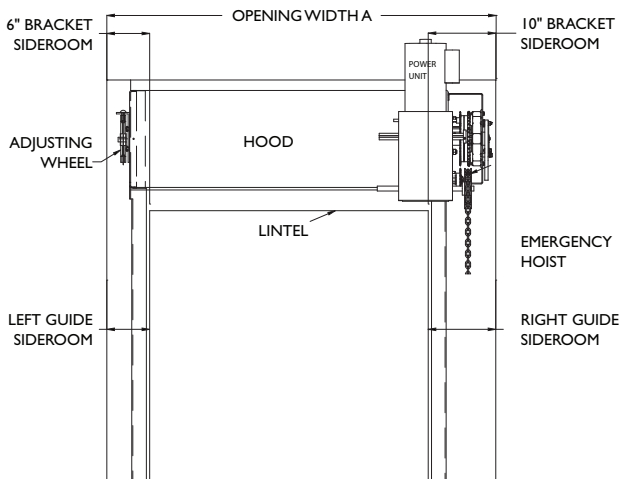

ELEVATION

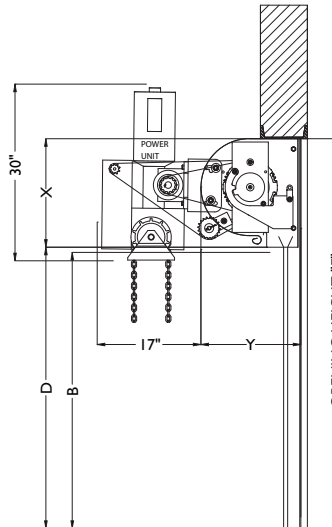

SECTION (UNDER LINTEL)

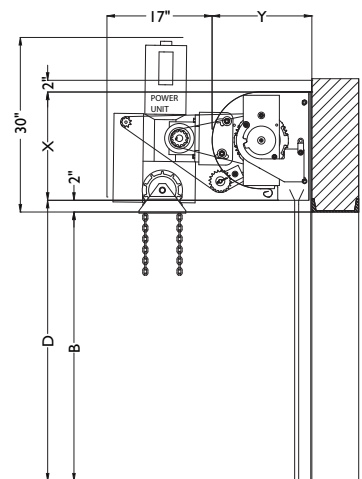

SECTION

### ANGLE GUIDES - FACE MOUNTED TO MASONRY

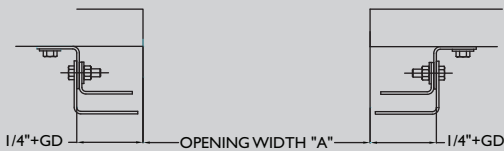

### ANGLE GUIDES - FACE MOUNTED TO STEEL

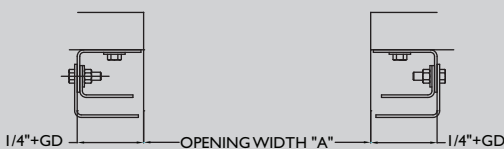

### ANGLE GUIDES - MOUNTED BETWEEN JAMBS

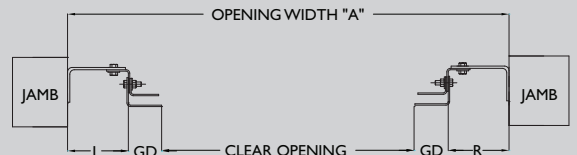

700C Series Door	
GD	WIDTH
2 1/8"	TO 13'6" WIDTH
2 13/16"	TO 20'0" WIDTH
3 1/4"	TO 24'0" WIDTH

NOTE: Dimensions are for general reference only and not for construction purposes.

### COMMON GUIDE MOUNTING OPTIONS

# ROLLING STEEL FIRE DOORS ACCESSORIES

## Slat Profile



## Standard Weatherseal Applications

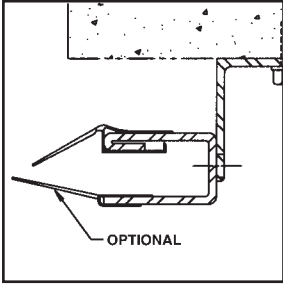

**To close space** between curtain and guides at jambs, flexible strip on guides contacts flat surface of curtain.

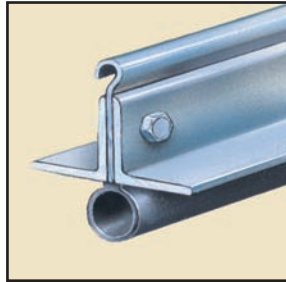

**Bottom bar with weatherseal**

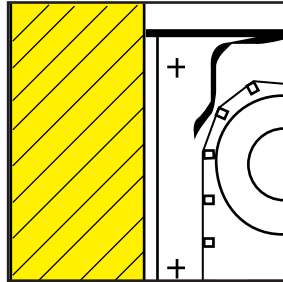

**To reduce air infiltration** at top of door; hood baffle attached to hood extends full width of door; Optional lintel weatherstripping will further reduce air passage when attached to the header.



# ROLLING STEEL FIRE DOORS

# 700C SERIES

## 700C Series (Face Mounted)

Width A	HEIGHT B (OPENING HEIGHT)															
	9'0"				TO 14'0"				TO 18'0"				TO 24'0"			
	BRACKET SIZE		SIDE ROOM		BRACKET SIZE		SIDE ROOM		BRACKET SIZE		SIDE ROOM		BRACKET SIZE		SIDE ROOM	
	X	Y	R	L	X	Y	R	L	X	Y	R	L	X	Y	R	L
<b>3" SLAT</b>																
<b>TO 24'0"</b>	16-1/2"	15"	10"	6"	20"	19"	10"	6"	22"	21"	10"	6"	24"	23"	10"	6"

## 700C Series (Between Jambs Mounted, Under Lintel)

Width A	HEIGHT B (OPENING HEIGHT)															
	9'0"				TO 14'0"				TO 18'0"				TO 24'0"			
	BRACKET SIZE		SIDE ROOM		BRACKET SIZE		SIDE ROOM		BRACKET SIZE		SIDE ROOM		BRACKET SIZE		SIDE ROOM	
	X	Y	R	L	X	Y	R	L	X	Y	R	L	X	Y	R	L
<b>3" SLAT</b>																
<b>TO 24'0"</b>	16-1/2"	15"	7-1/6"	9-1/6"	18-1/2"	17"	7-1/6"	9-1/6"	22"	21"	7-1/6"	9-1/6"	24"	23"	7-1/6"	9-1/6"
<b>20'0" TO 24'0"</b>	16-1/2"	15"	7-1/2"	10-1/4"	18-1/2"	17"	7-1/2"	10-1/4"	22"	21"	7-1/2"	10-1/4"	25"	25"	7-1/2"	10-1/4"

NOTE: Dimensions are for general reference only and not for construction purposes.

The Door & Access Systems Manufacturers Association (DASMA) supports periodic inspection of Fire Door assemblies as stated in the National Fire Protection Association Standard 80.

ULC US ROLLING FIRE DOOR NO. [ ]  
 FIRE RATING: [ ] HRS  
 Wayne Dalton SERIAL NUMBER: [ ]  
ROLLING DOOR DIVISION 1481 DUNDAS ST. E. DALLON, ON M6H 1R9 528-5110-59

ULC US OVERSIZE ROLLING FIRE DOOR NO. [ ]  
 FIRE RATING: [ ] HRS  
 Wayne Dalton SERIAL NUMBER: [ ]  
ROLLING DOOR DIVISION 1481 DUNDAS ST. E. DALLON, ON M6H 1R9 528-5110-59

ULC LISTED FIRE DOOR RATING: [ ] HR. PORTE COUPE - FEU  
 NO. [ ]  
 KINNEAIR INDUSTRIES CORPORATION LIMITED  
CAMBRIDGE ONTARIO

FACTORY MUTUAL



COMMERCIAL DOORS & OPERATORS

# ROLLING STEEL FIRE DOORS

# FIRESTAR™ 700C SERIES

**Note to specifiers:** Words in brackets indicate frequently specified and highly recommended options.

## PART I – GENERAL

### 1.01 Work Included

- A. The opening will be equipped with Wayne-Dalton 700C Series rolling doors.

### 1.02 Related Work

- A. Opening preparation, miscellaneous or structural metal work, access panels, finish or field painting, field electrical wiring, wire, conduit, fuses, and disconnect switches are in the Scope of Work of other divisions or trades.

### 1.03 Reference Standards

- A. **ANSI/DASMA 204** – American National Standards Institute Specifications for rated fire rolling doors published by Door & Access Systems Manufacturers Association International.
- B. **ASTM A123** – Zinc [hot-dipped galvanized] coatings on iron and steel products.
- C. **ASTM A229** – Steel wire, oil-tempered for mechanical springs.
- D. **ASTM A-653-94** – Steel sheet, zinc-coated [galvanized] by the hot-dipped process, commercial quality.
- E. **UL10B** – Underwriters' Laboratories (UL) Fire Tests of Door Assemblies
- F. **NFPA 80** – National Fire Protection Agency – Fire Doors and Other Opening Protectives
- G. **ASTM C 612** – Standard specification for Mineral Fiber Insulation
- H. **ASTM E-136** – Non-combustible rating for mineral wool
- I. **ASTM E-84** – Flame spread and smoke development, surface burning characteristics of building materials.

### 1.04 Quality Assurance

- A. Rolling doors and all accessories and components required for complete and secure installations shall be manufactured as a system from one manufacturer.

### 1.05 Systems Description

- A. Rolling Door: Type:  
**Model 700C**
- B. Mounting: [steel][masonry][drywall over minimum 1/6-gauge steel studs or wood studs] jambs
- C. Operation: [chain hoist] [motor]  
[motor with chain hoist]
- D. Material: Galvanized steel with polyester finish paint

### 1.06 Submittals

- A. Shop Drawings: Clearly indicate the following:
  - 1. All details required for complete operation and installation.
  - 2. Hardware locations.
  - 3. Type of metal and finish for door sections.
  - 4. Finish for miscellaneous components and accessories.
- B. Product Data: Indicating manufacturer's product data, and installation instructions.

### 1.07 Delivery, Handling, Storage

- A. Deliver products in manufacturer's original containers, dry, undamaged, seals and labels intact.
- B. Store and protect products in accordance with manufacturer's recommendations.

### 1.08 Warranty

- A. Standard manufacturer's one year warranty against defects in material and workmanship.

## PART II – PRODUCTS

### 2.01 Curtain

- A. Curtain will be composed of interlocking #14 flat slats [22, 20, 18 gauge galvanized steel] [22, 20 stainless steel] slats with [24-gauge] [22-gauge] back slats, roll-formed per ASTM standards. The area between the #14 exterior slat and the back slat will be filled by non-combustible mineral wool insulation with 0 flame spread, 0 smoke development, providing an R-value of 5 (U = 0.2). Ends of alternate slats will be fitted with metal endlocks.
- B. Bottom Bar will consist of two equal steel [stainless steel] angles, .121" minimum thickness, to stiffen curtain, with optional astragal. When required for additional security, provide [slide bolts] [cylinder locks] on the bottom bar operable from [coil side] [both sides].

### 2.02 Guides

- A. Guides will be roll-formed steel structural grade, three angle assembly of steel [stainless steel] to form a slot of sufficient depth to retain curtains in guides and to allow expansion at all bolt connections. (Perimeter brush seals may be installed to reduce smoke/air infiltration around door opening)

### 2.03 Brackets

- A. Brackets will be of 3/16" [1/4"] minimum thick steel plates, with permanently sealed ball bearings. Designed to enclose ends of coil and provide support for counterbalance pipe at each end.

### 2.04 Counterbalance

- A. Curtain to be coiled on a pipe of sufficient size to carry door load with deflection not to exceed .033" per foot of door span and to be correctly balanced by helical springs, oil tempered torsion type. Cast iron barrel plugs will be used to anchor springs to tension shaft and pipe.

### 2.05 Hood

- A. Hood will be minimum 24-gauge [galvanized] [stainless steel] sheet metal, flanged at top for attachment to header and flanged at bottom to provide longitudinal stiffness. Hood will enclose curtain coil and counterbalance mechanism. All FM hoods will be furnished with a steel hood baffle.

### 2.06 Finish

- A. Shop coat of rust inhibitive primer on non-galvanized surfaces and operating mechanisms. Guides and bracket plates will be coated with a flat black prime paint. Stainless steel finish available. Curtain color will be [white] [blue] [gray] [beige] [brown] [white, blue, beige, brown only available as 22 gauge]. Powder coating is available in 180 colors.

### 2.07 Operation

- A. Door will be operated by means of [chain hoist with gear drive reduction] [motor operation]. Optional [electrical] [pneumatic] sensing edge to be attached to bottom bar to [stop] [stop and reverse] the door when it contacts an object during the closing cycle.

### 2.08 Release Mechanism

- A. Doors will be equipped with FireStar release mechanism, requiring only one cable to be routed to the operated side (cable not required to be routed to adjusting wheel side.) Doors will close by a thermally actuated link rated at 165 degrees F, or by an optional listed releasing device, or by manually operating the release handle. All spring tension shall be maintained

when the release mechanism is activated. After closing by manual operation of release handle, the door shall be able to be reset by one person from one side of the door (re-engaging the release handle).

### 2.09 Governor

- A. If required by the size of the door, a viscous governor will be furnished to regulate the rate of descent of the door in a quiet manner. It will be the engagement type which is not engaged during normal door operation, but which after cable release, will retard the speed during automatic door closure to under 2' per second and not less than 6" per second.

### 2.10 Labels

- A. Rolling fire doors will bear the ¾ (three-quarter) hour; 1½ (one and one-half) hour; or 3 (three) hour label provided they are <= 12' high, <= 13'6" wide. They will bear an oversize tag if they are over 12' high or 13'6" wide. Rolling fire doors will be manufactured in strict accordance with the requirements of Underwriters Laboratories-listed procedures or Factory Mutual-approved procedures, and will bear the UL or FM label (tag). FM label is available for the 3-hour fire door only.

### 2.11 Locking

- A. [Chain-hoist door will have chain keepers suitable for padlocks by others.] [Electric-motor operation doors will lock through the operator gearing.] [Cylinder locks can be provided with the doors.]

**Note:** When specifying locks on electric-motor operated doors, electric interlocks should also be specified to prevent operation when lock bolts are engaged in the guides, thus preventing damage to the curtain and/or operator.

## PART III – EXECUTION

### 3.01 Installation

- A. General:
    - 1. Install the rolling fire doors in accordance with Wayne-Dalton Corp. instructions and standards and in accordance with the standards of the National Fire Protection Association Standard 80 (NFPA 80). Installation and annual maintenance will only be by a trained door systems technician.
    - 2. Verify that existing conditions are ready to receive rolling door work.
    - 3. Beginning of rolling door work means acceptance of existing conditions.
  - B. Fit, align, and adjust rolling door assemblies level and plumb for smooth operation.
  - C. Upon completion of final installation, lubricate, test and adjust doors to operate easily, free from warp, twist or distortion and fitting for entire perimeter.
- Note:** Architect may consider providing a schedule when more than one rolling door or opening type is required.

### 3.02 Testing

- A. Rolling steel fire doors will be drop-tested in accordance with NFPA 80 and witnessed, attesting to their successful operation at the time of installation.

### 3.03 Maintenance

- A. Per NFPA 80, paragraph 15-2.4.3: All horizontal or vertical sliding and rolling fire doors shall be inspected and tested annually to check for proper operation and full closure. Resetting of the release mechanism shall be done in accordance with the manufacturer's instructions. A written record shall be maintained by the building owner and made available to the authority having jurisdiction.

Because of continuing product improvements, we reserve the right to change the product specifications and designs without prior notice.

## Distributed By:



COMMERCIAL DOORS & OPERATORS

For technical information, visit:

[www.wayne-dalton.com/commercial](http://www.wayne-dalton.com/commercial)

© 2008 Wayne-Dalton Corp. • One Door Drive • Mt. Hope, Ohio 44660 • 800-255-3046

Mt. Hope, OH • Dalton, OH • Trail, OH • Pensacola, FL • Portland, OR

Printed in U.S.A.

Item #333069 Revised 4/2008